

McIntosh

MX 114



SERVICE INFORMATION

STARTING WITH SERIAL NO. 10V01

McINTOSH LABORATORY INC. 2 CHAMBERS STREET BINGHAMTON, NEW YORK

MX 114

ELECTRICAL SPECIFICATIONS

TUNER SECTION

USABLE SENSITIVITY

Better than $2.5\mu\text{V}$ (IHF usable sensitivity)

SIGNAL TO NOISE RATIO

Better than 65dB

HARMONIC DISTORTION

Mono, less than 0.5%. Stereo, less than 0.8%.

FREQUENCY RESPONSE

Flat from 20Hz to 20kHz with standard de-emphasis and 19kHz pilot filter

CAPTURE RATIO

Better than 1.5dB

SPURIOUS REJECTION

90dB or greater

IMAGE REJECTION

75dB or greater (at 100MHz)

STEREO SEPARATION

Better than 30dB at 1kHz

PREAMPLIFIER SECTION

FREQUENCY RESPONSE

$\pm 0.5\text{dB}$, 20Hz to 20,000Hz

DISTORTION

Less than 0.1% at 2.5 volts 20Hz to 20kHz

INPUT SENSITIVITY (phono 1 and phono 2)

2 millivolts for 2.5 volts output at 1kHz

INPUT SENSITIVITY (aux, tape)

0.25 volts for 2.5 volts output

HUM AND NOISE (phono 1 and phono 2)

72dB below 10 millivolt input

HUM AND NOISE (aux, tape)

85dB below rated output

OUTPUT (main)

2.5 volts with rated input. Up to 10 volts can be developed without distortion. FM will produce up to 10 volts output at 100% modulation.

OUTPUT (tape)

0.25 volts with rated input. Phono input signal of 10 millivolts produces 1.2 volts output. FM will produce 1 volt output at 100% modulation.

OUTPUT (center channel)

2 volts with rated input to both channels

BASS CONTROL

-18dB to +16dB at 20Hz

TREBLE CONTROL

$\pm 20\text{dB}$ to 20,000Hz

LF FILTER

Flat or roll off below 50Hz, down 12dB at 20Hz

HF FILTER

Flat or roll off above 5000Hz, down 12dB at 20,000Hz

TUNER SECTION

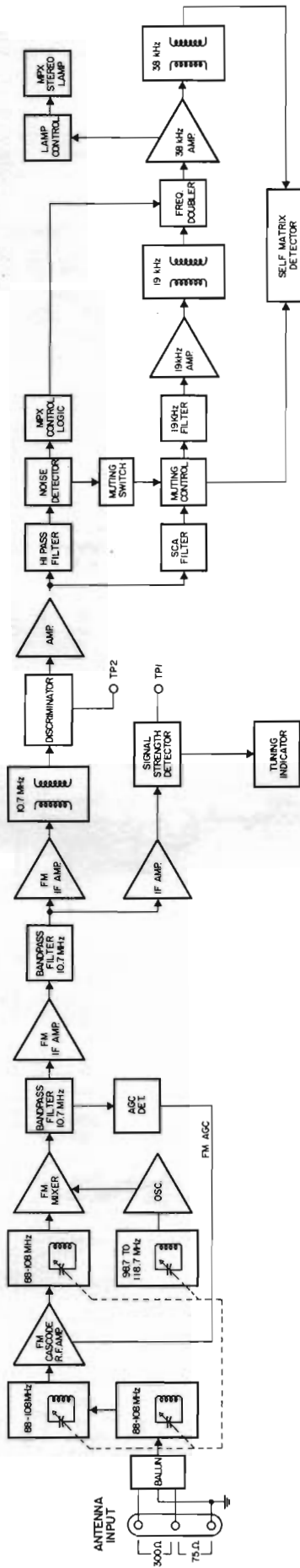

DE EMPHASIS
A
B
LEFT FM OUTPUT RIGHT FM OUTPUT
TO PREAMPLIFIER INPUTS

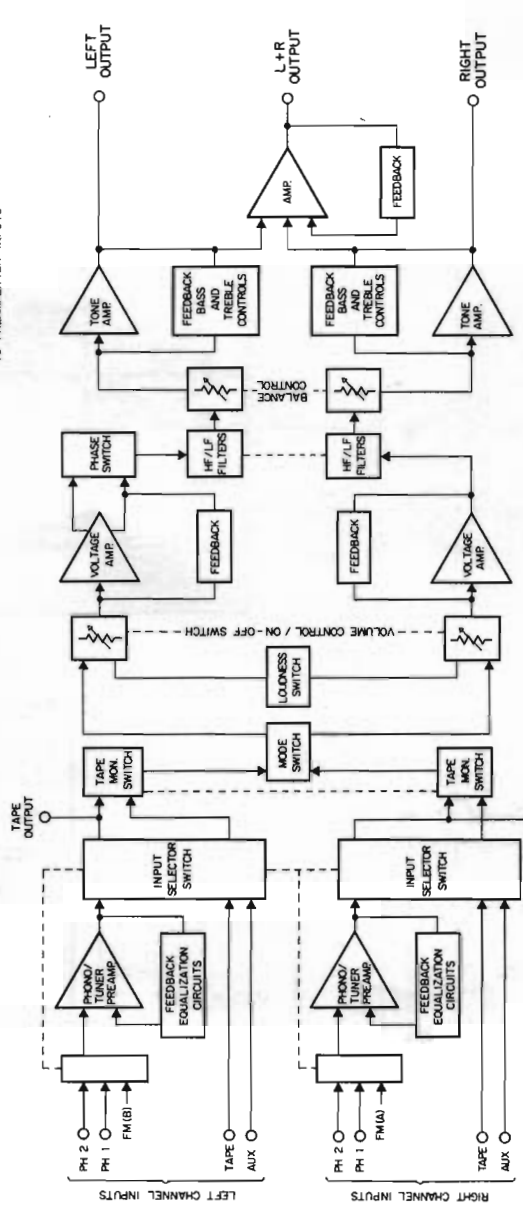

PREAMPLIFIER SECTION

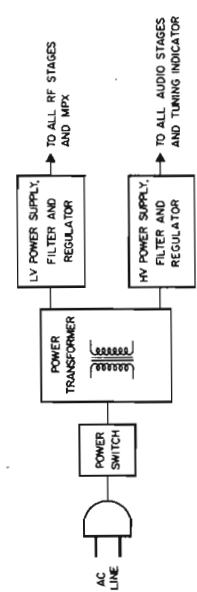

POWER SUPPLY

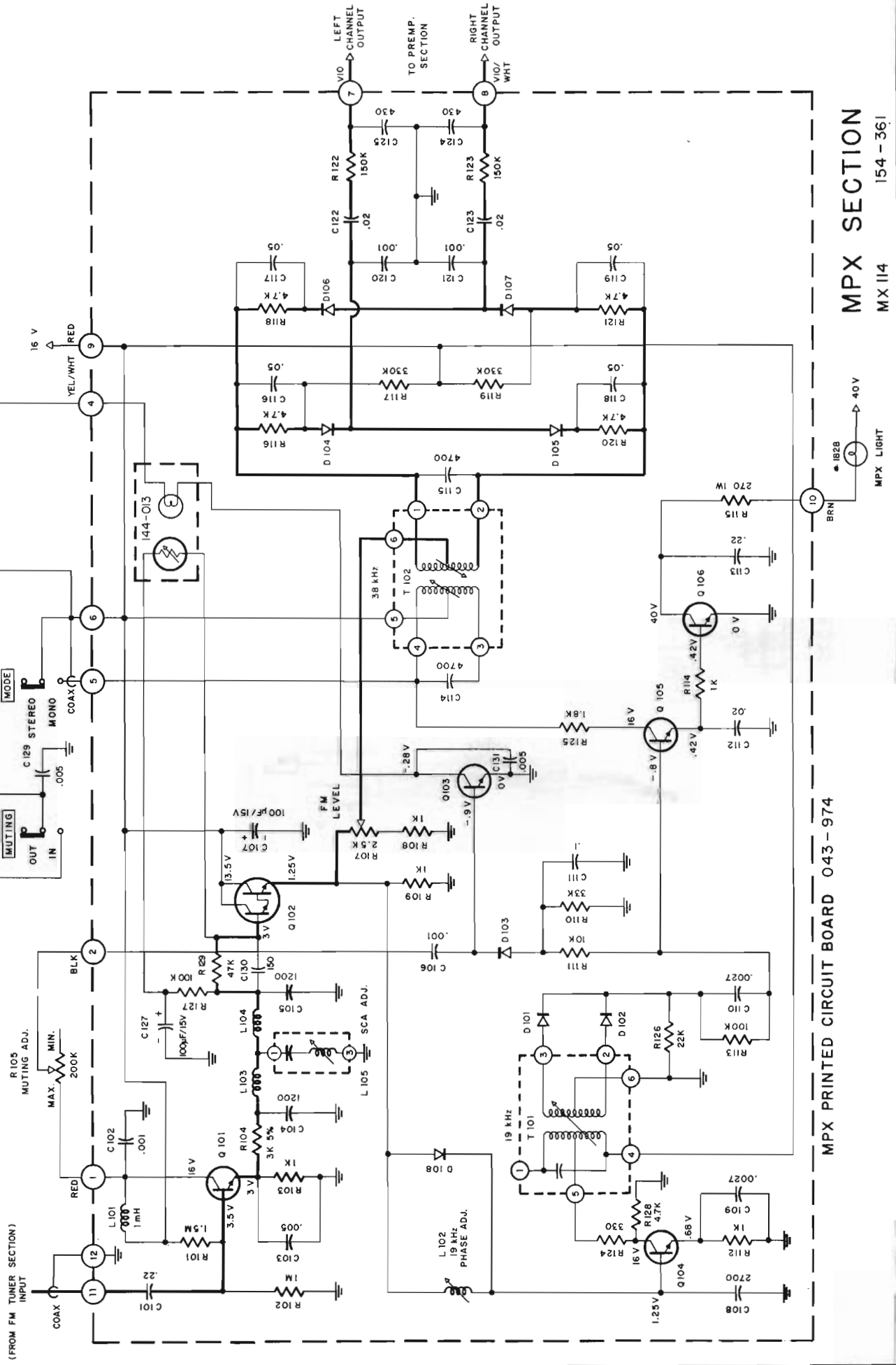

MPX PRINTED CIRCUIT BOARD 043-974

MPX SECTION
MX 114 154-361

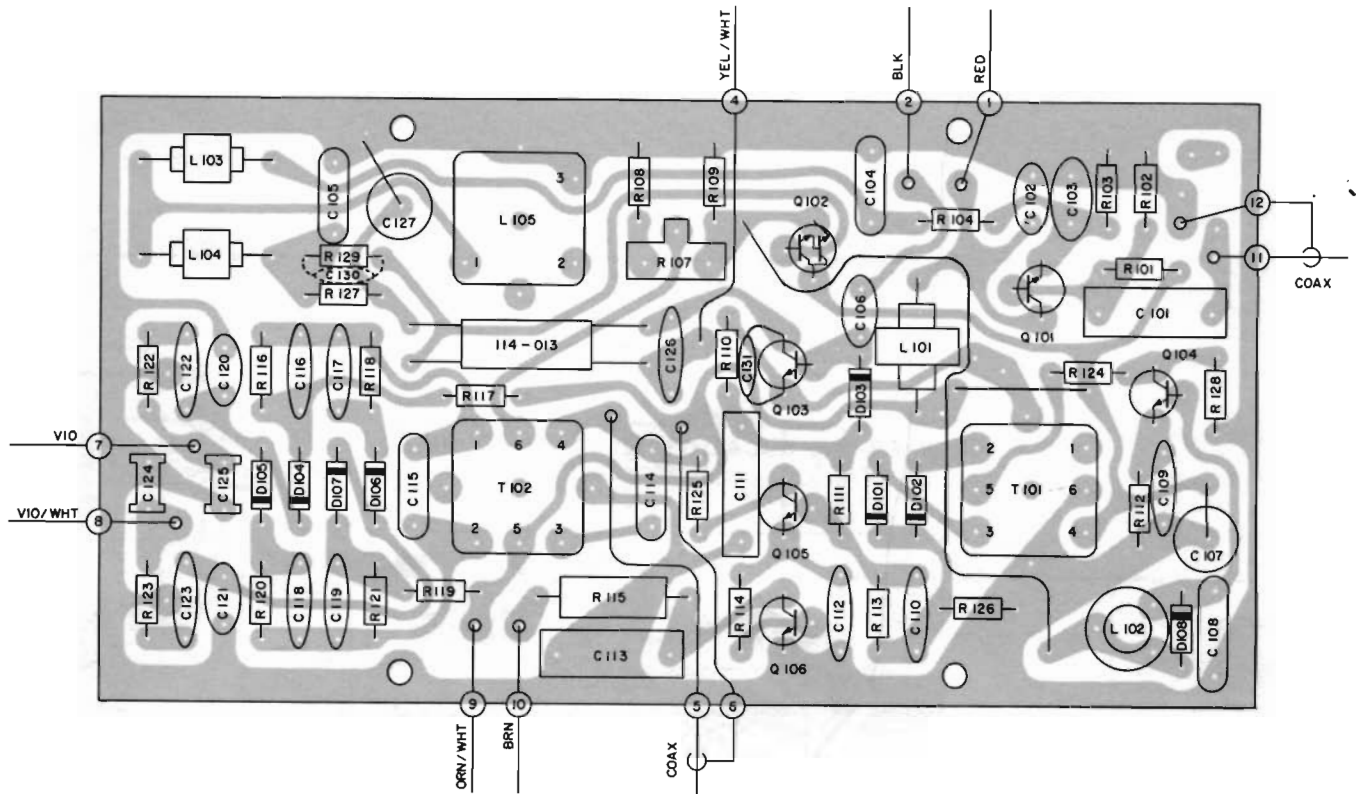

MPX PRINTED CIRCUIT BOARD 043-974

POINTER DRIVE

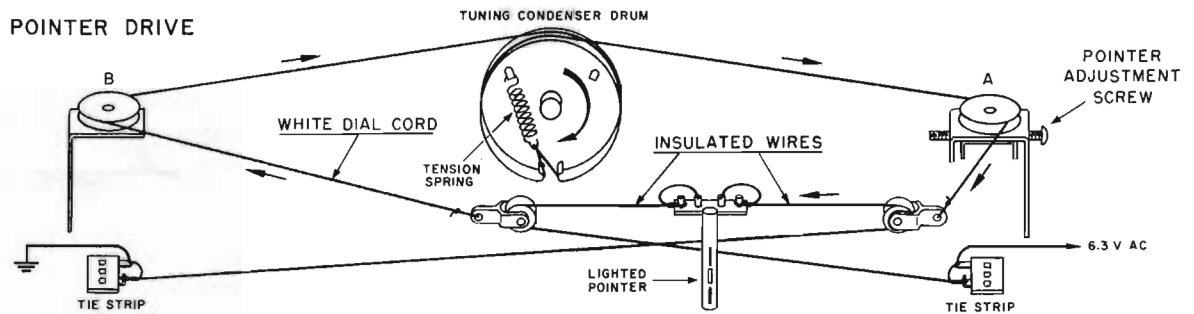

- Step 1 Before stringing unit, turn pointer adjustment screw until pulley "A" is in the center of its travel.
- Step 2 String unit as shown.
- Step 3 After stringing unit, turn tuning shaft until pointer is as far to the left as it will go. Turn the pointer adjustment screw until the pointer coincides with the zero bar of the logging scale.
- Step 4 Turn the tuning knob making the pointer move back and forth from one end of the dial scale to the other. Return pointer to the far left and, if necessary, re-adjust pointer position.

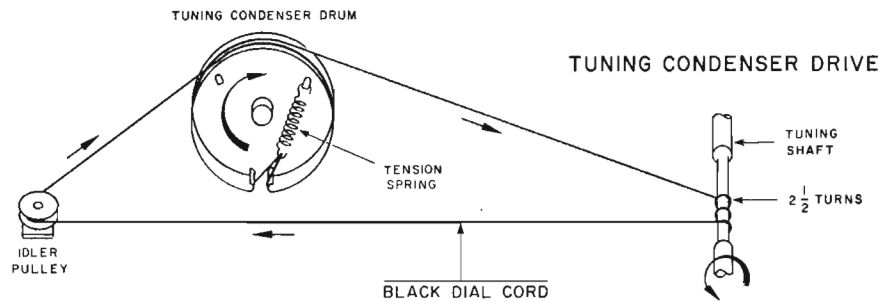

DIAL CORD SEQUENCE

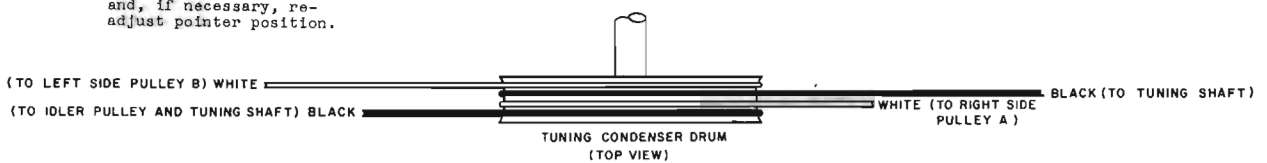

POINTER DIAL STRINGING

MIXER AND LOCAL OSCILLATOR P.C. BOARD
043-953

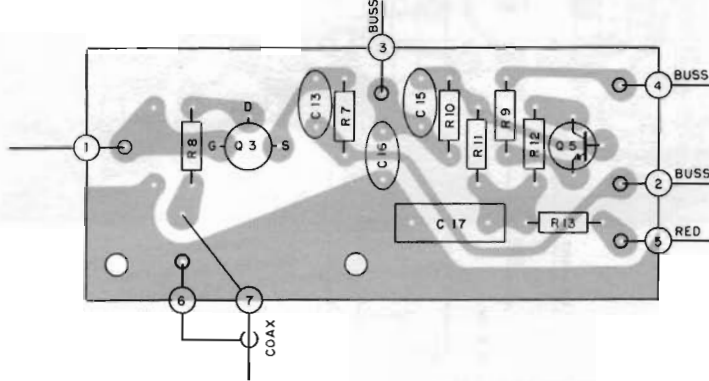

IF PRINTED CIRCUIT BOARD 043-954

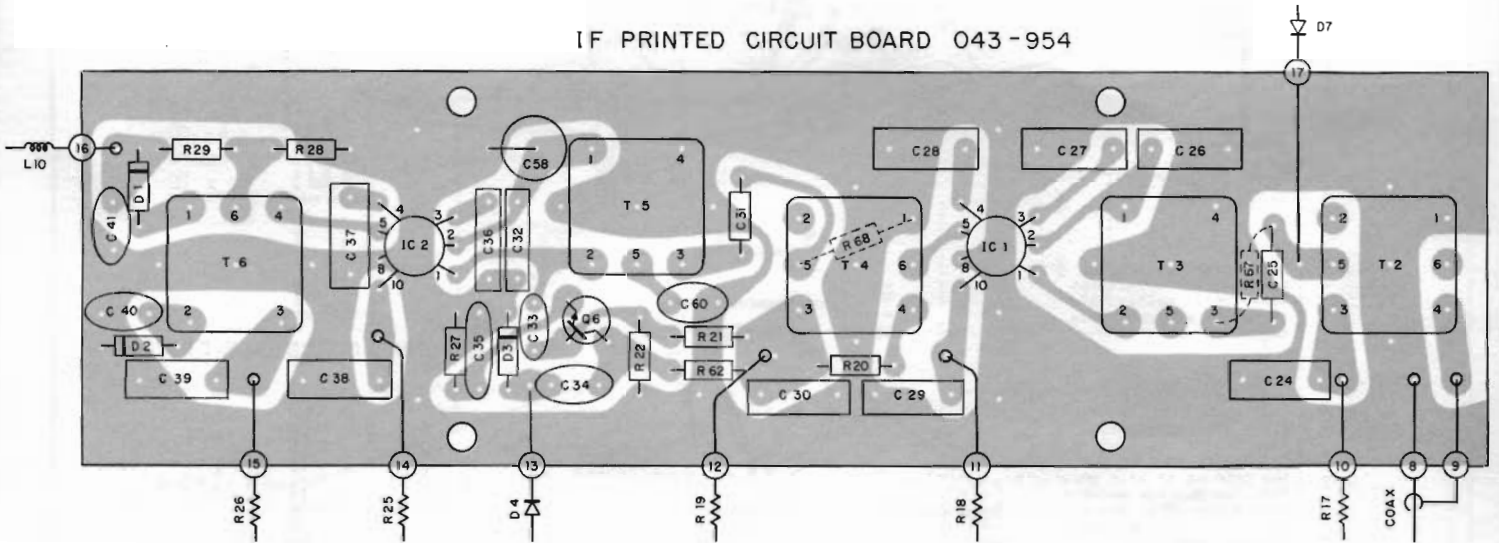

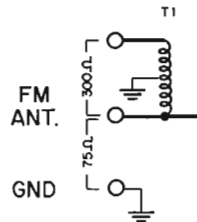

RF CHASSIS

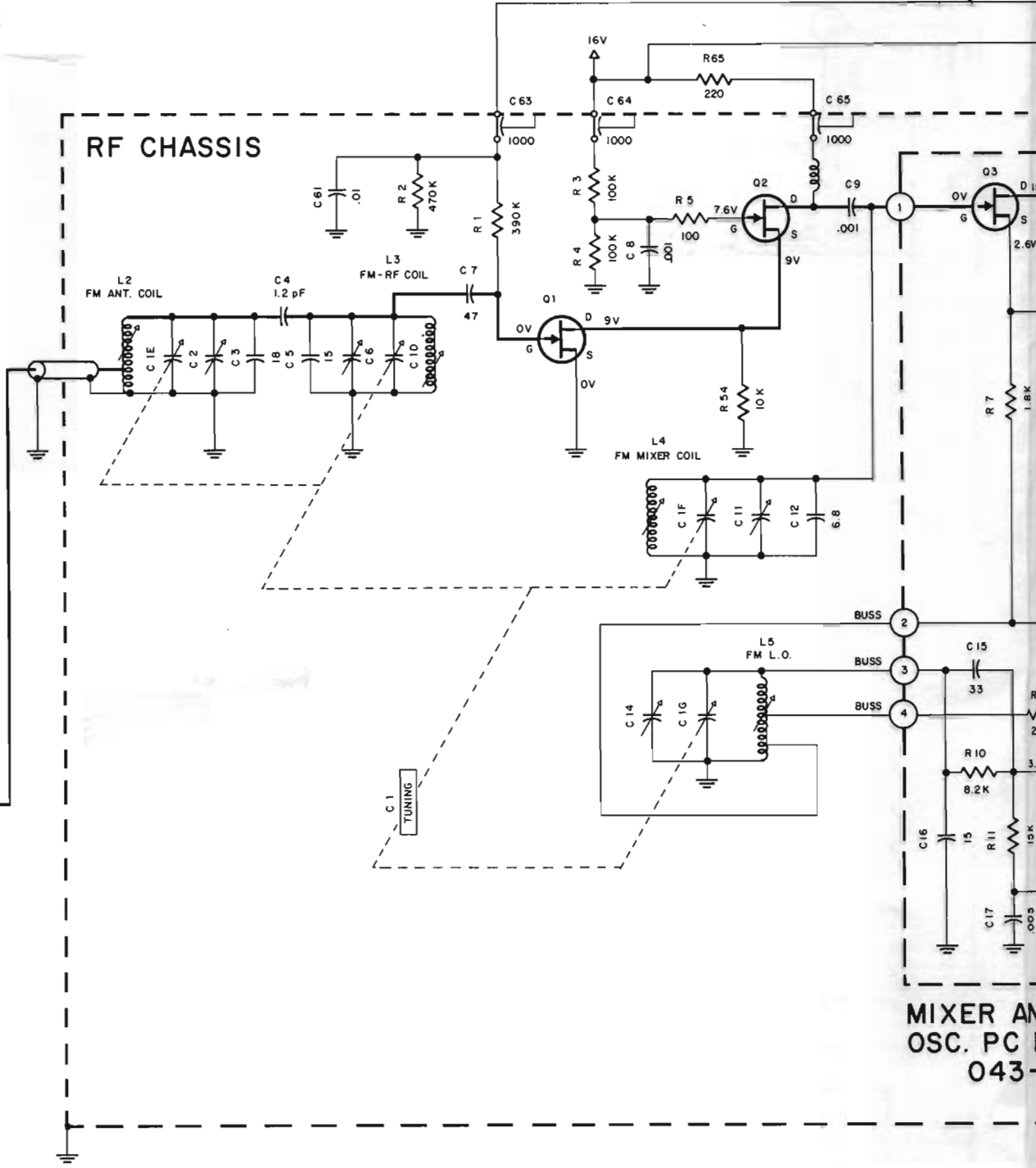

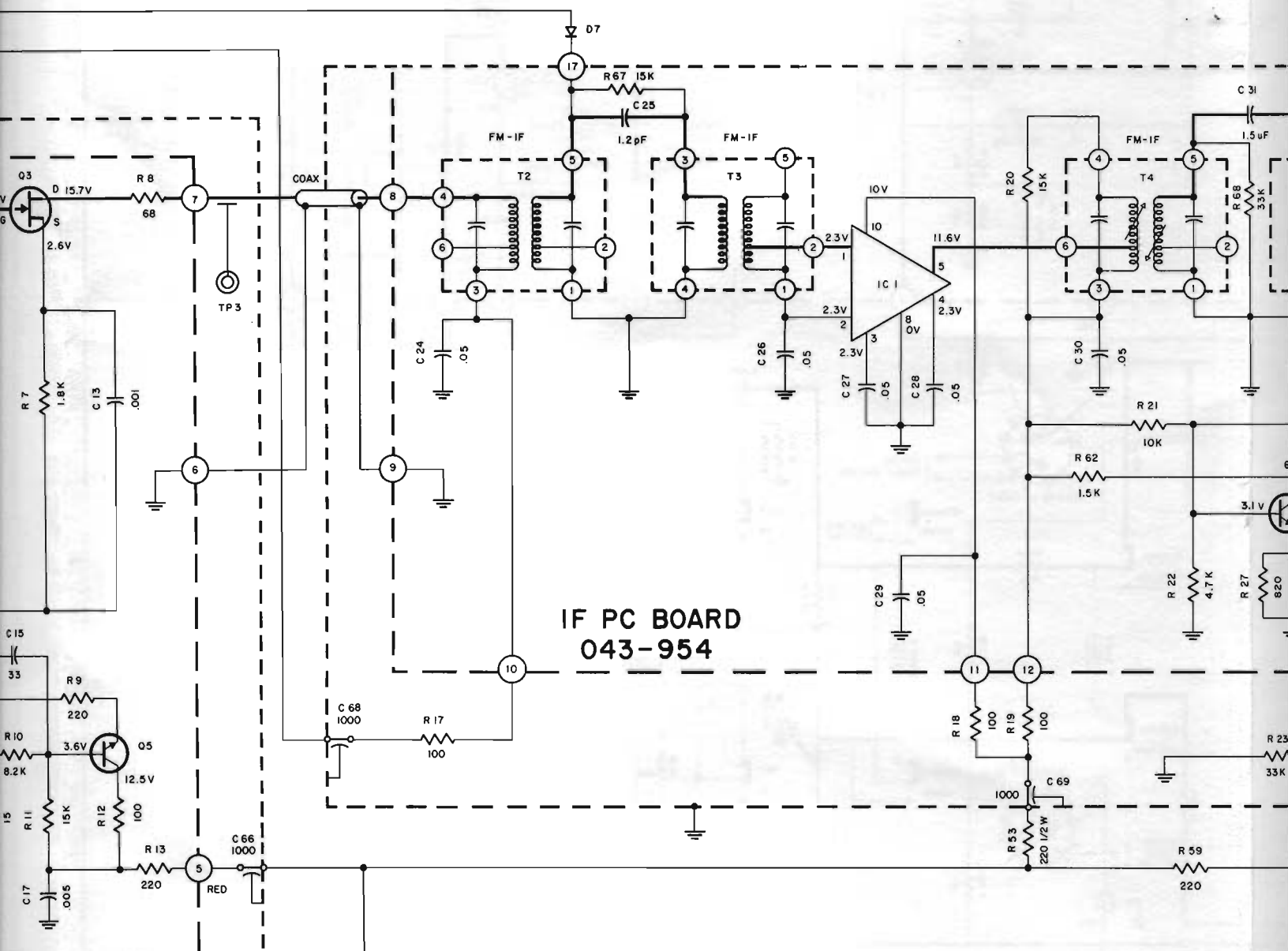

**ER AND LOCAL
PC BOARD
043-953**

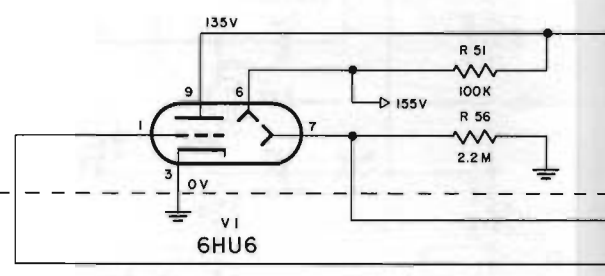
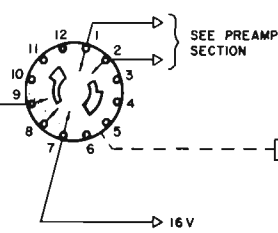

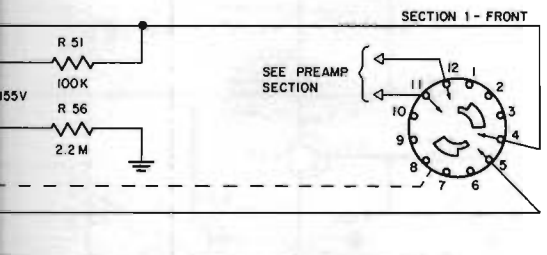
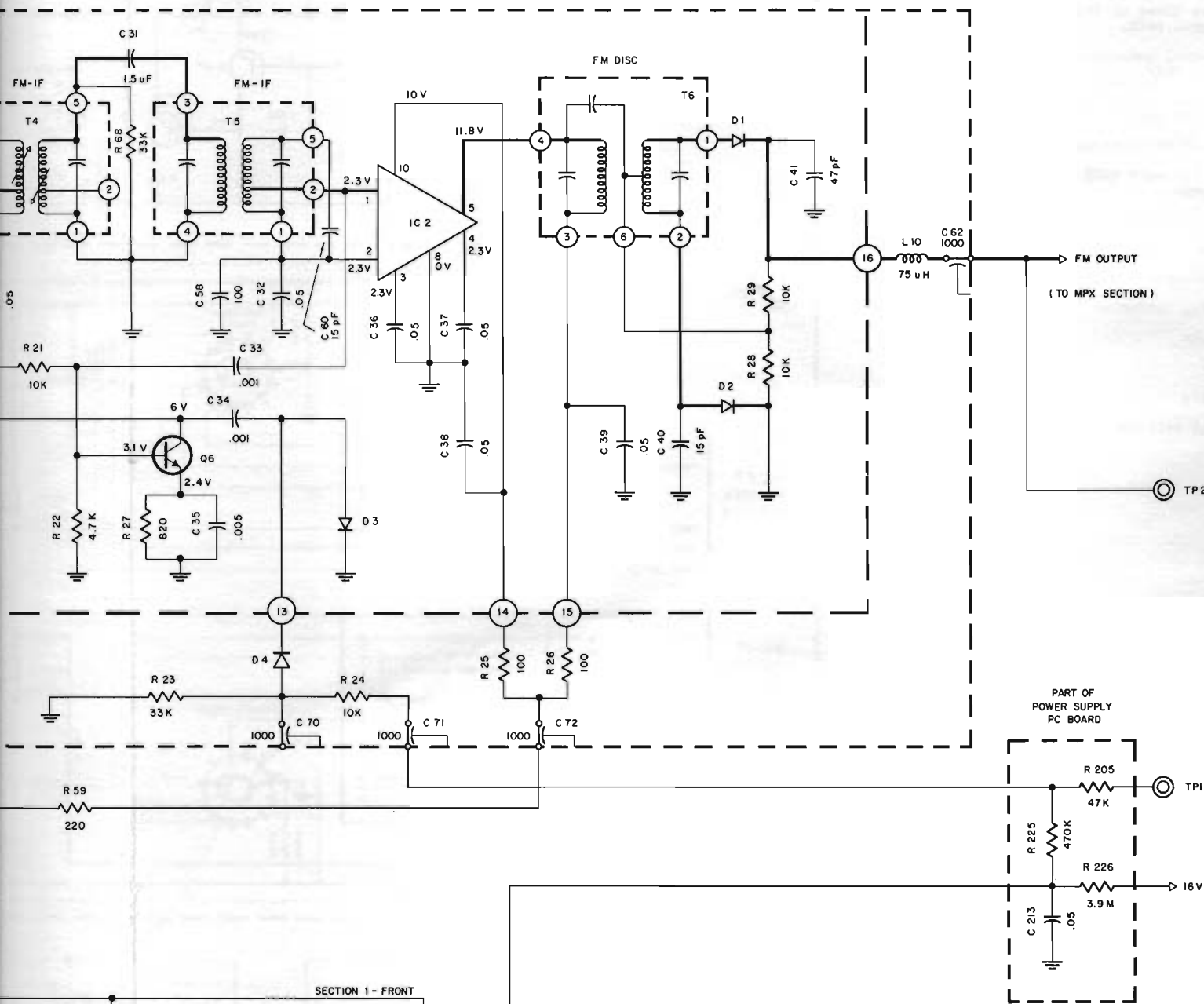

FM TUNER SECTION

SCHEMATIC NOTES

Unless otherwise specified: Resistance values are in ohms, 1/4 watt, and 10% tolerance; capacitance values smaller than 1 are in microfarads (μF); capacitance values greater than 1 are in picofarads (pF); inductors are in microhenries (μH).

Printed circuit board components are outlined on the schematics by dotted lines. The circled numbers around the dotted lines correspond to the numbers on the PC Board layouts.

The heavy lines on the schematics denote the primary signal path.

The terminal numbering of rotary switches is for reference only.

All voltages indicated on the schematics are measured under the following conditions:

- Use of an 11 megohm input impedance VTVM.
- All voltages $\pm 10\%$ with respect to chassis ground.
- No signal at input or antenna terminals.
- AC input at 117 volts, 50/60Hz.
- Front panel controls at:

Tuning indicator	100MHz (no signal)
Volume	Fully CCW
Mode	Stereo
Muting	Out
Input Selector	FM
Panel Lights	Bright

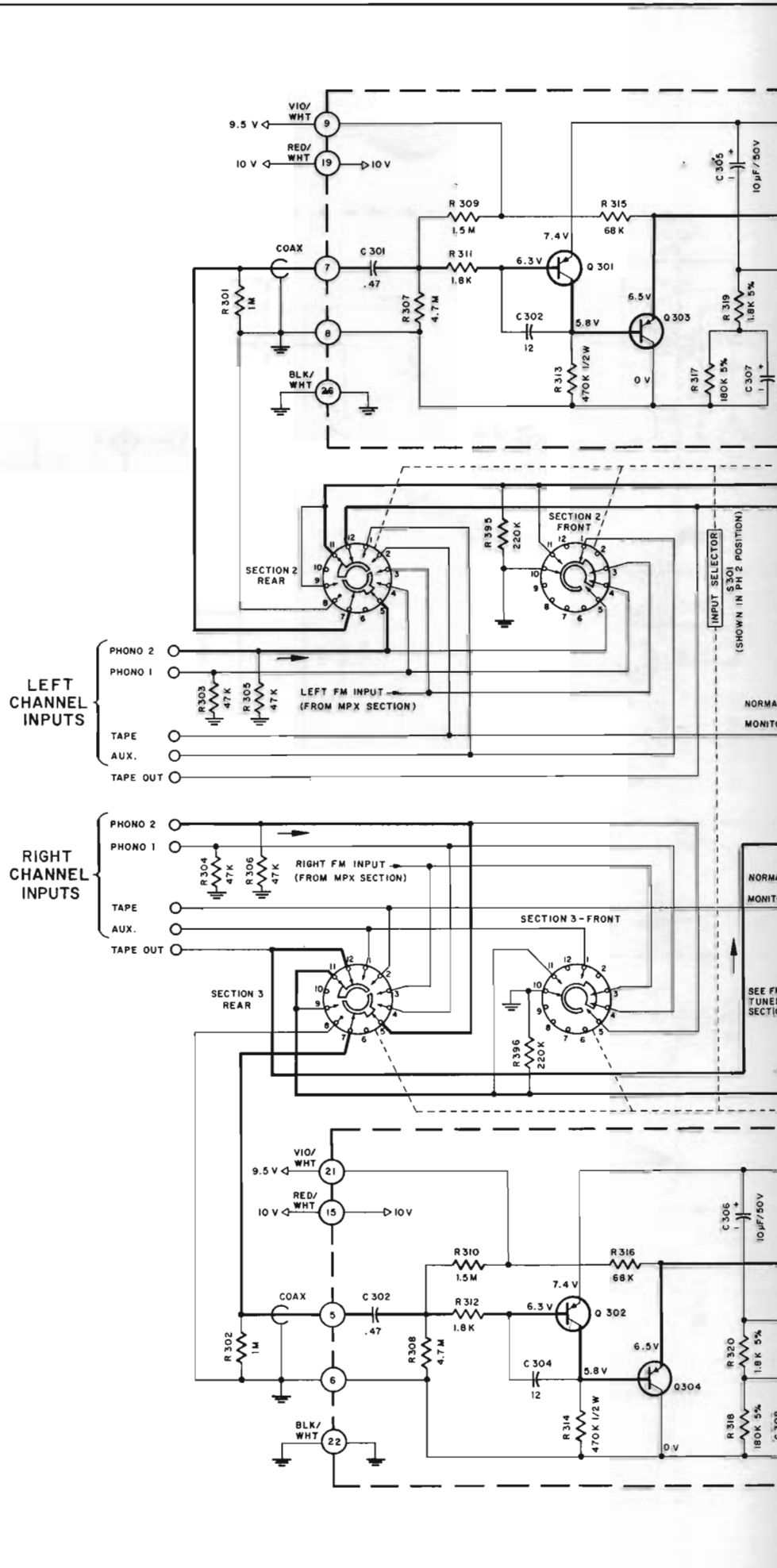

LEFT CHANNEL PREAMP. PRINTED CIRCUIT BOARD

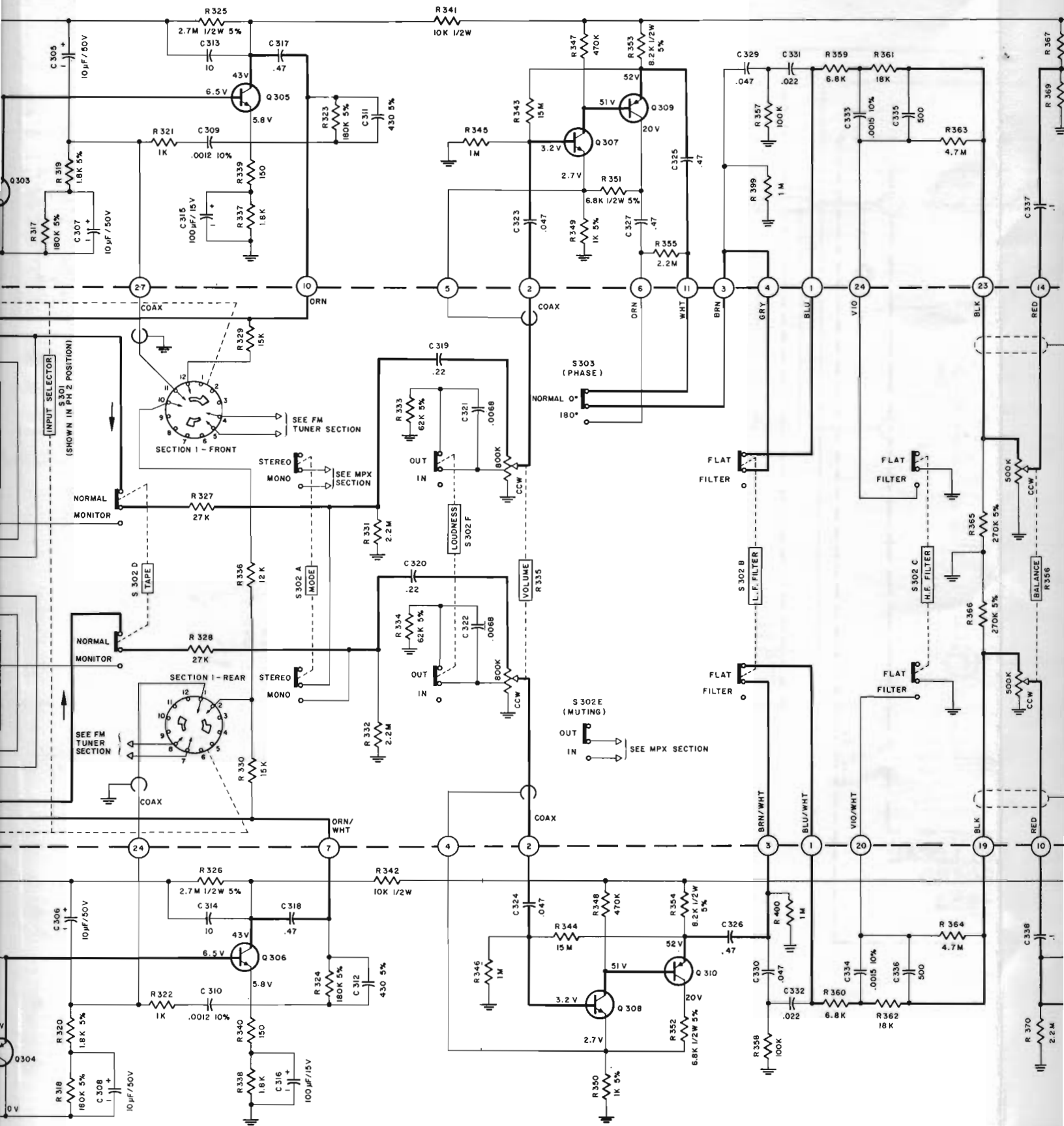

RIGHT CHANNEL PREAMP. PRINTED CIRCUIT BOARD

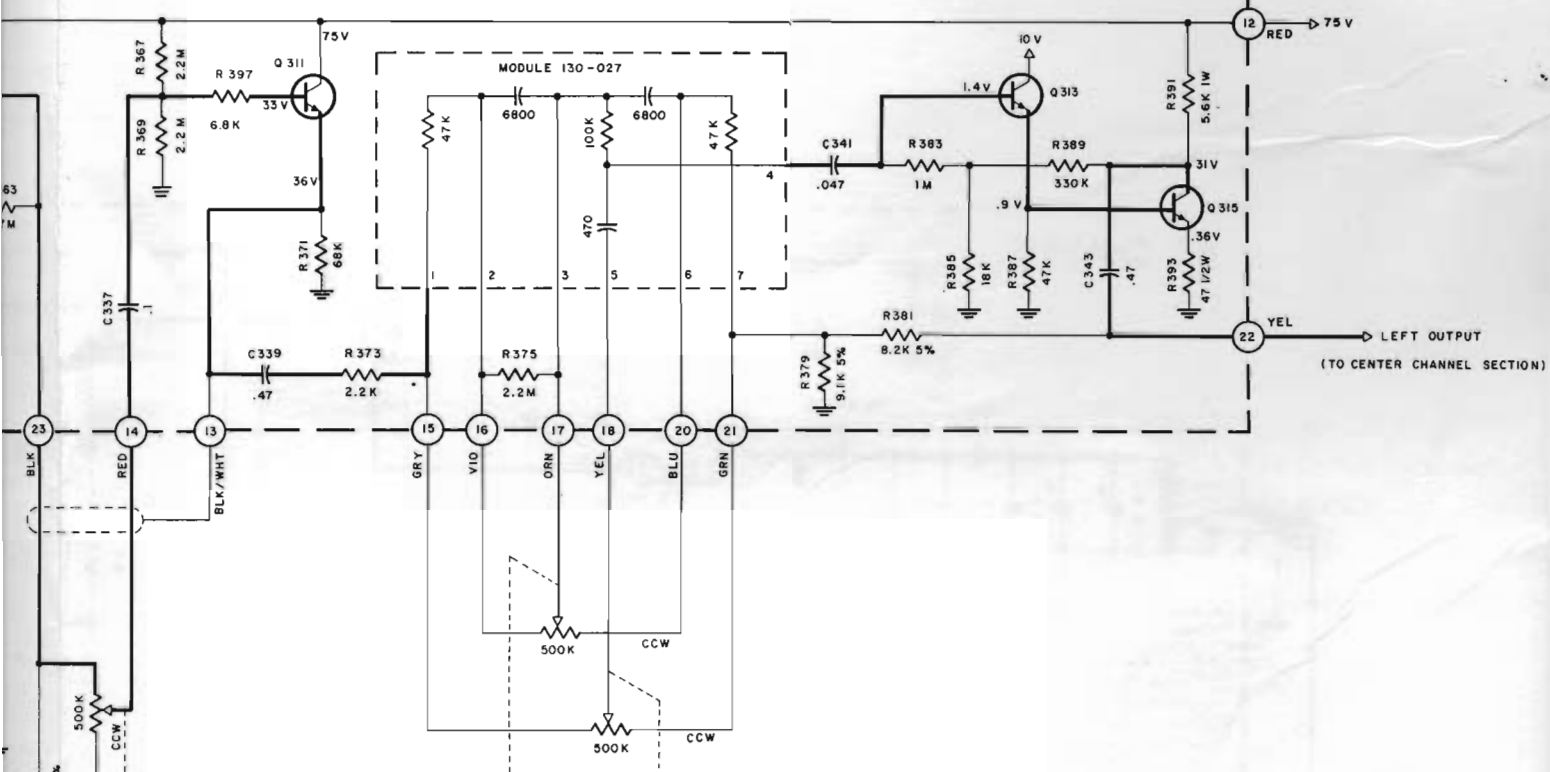

PREAMP. SECTION
MX 114 154 - 359

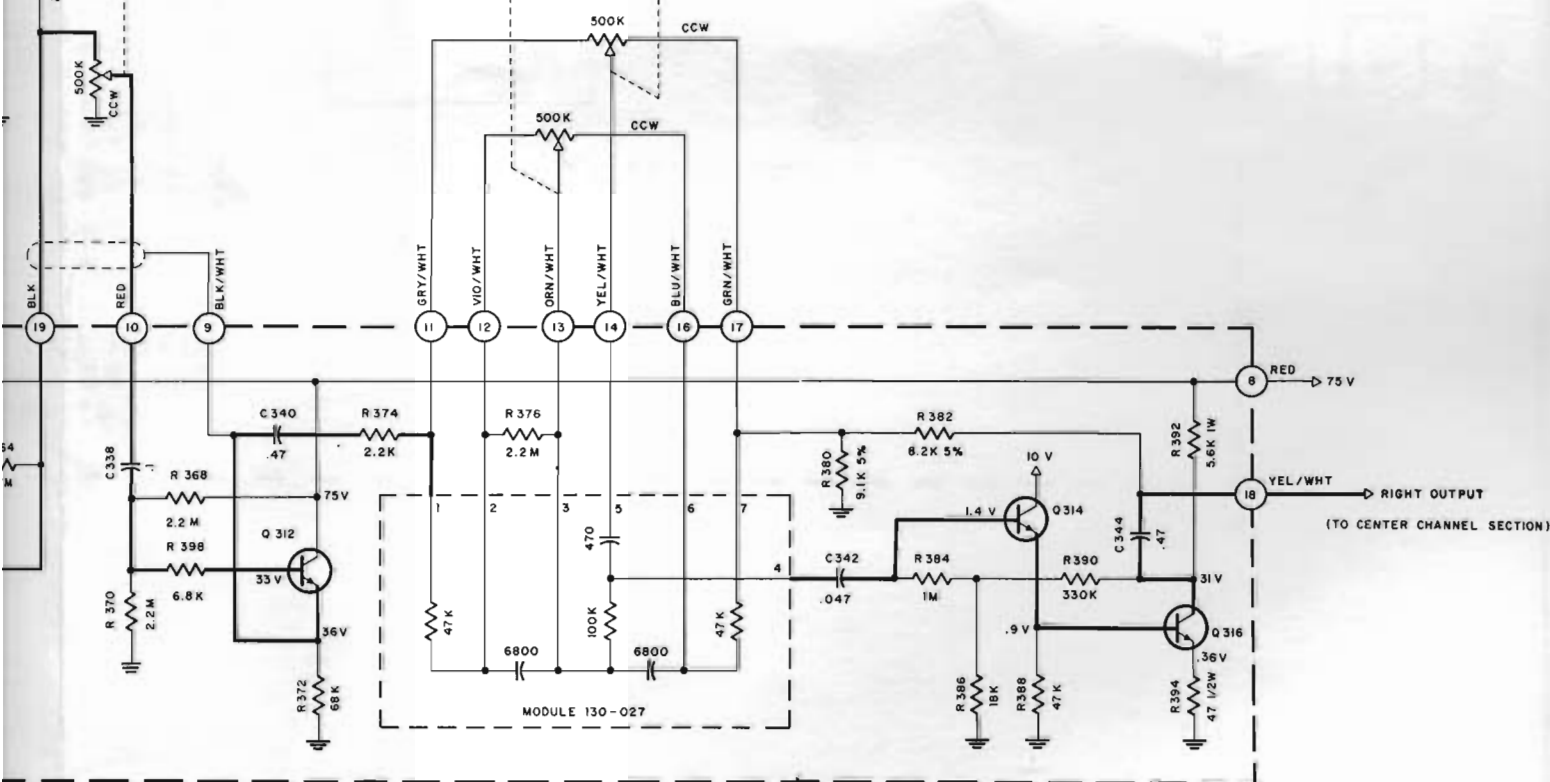

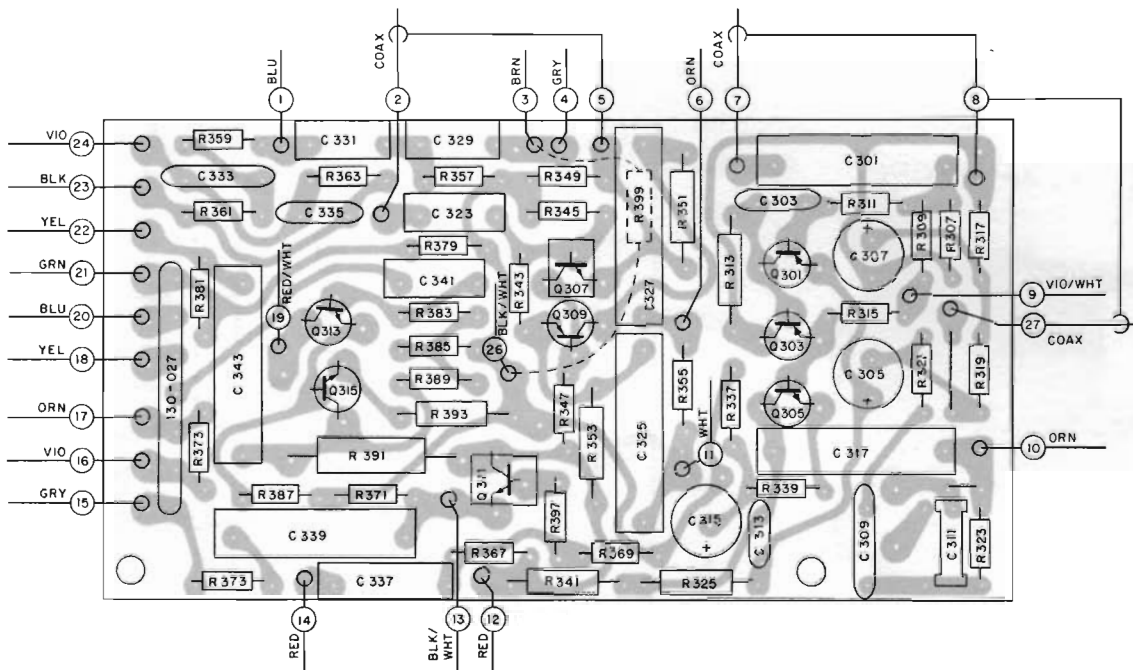

LEFT CHANNEL PREAMP PRINTED CIRCUIT BOARD O43-991

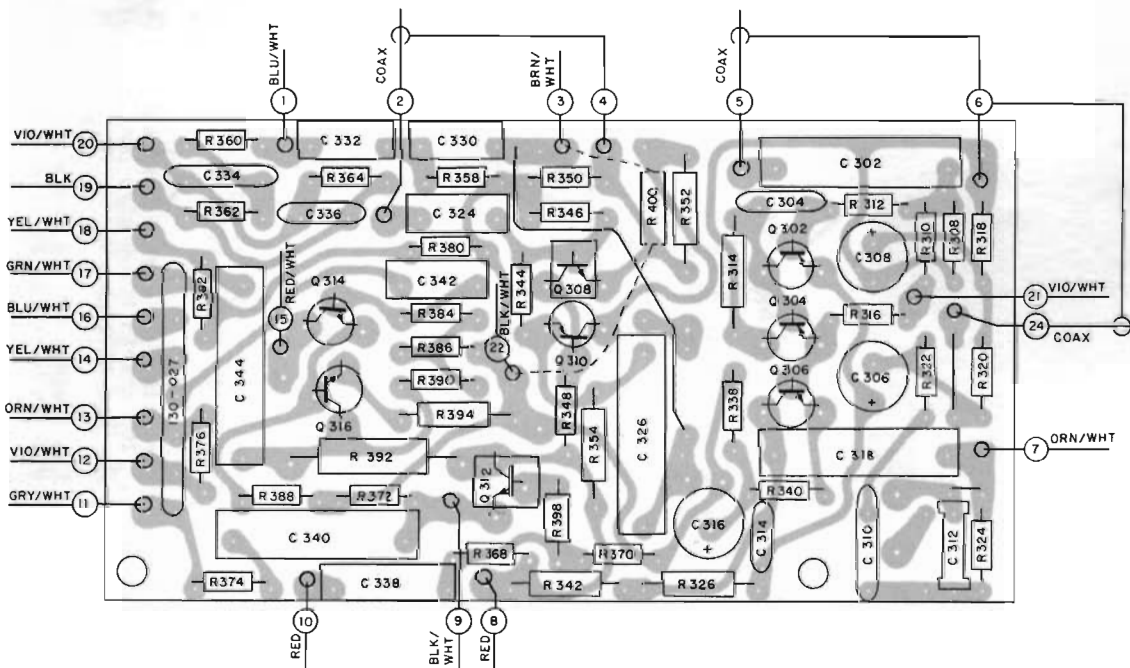

RIGHT CHANNEL PREAMP. PRINTED CIRCUIT BOARD O43-992

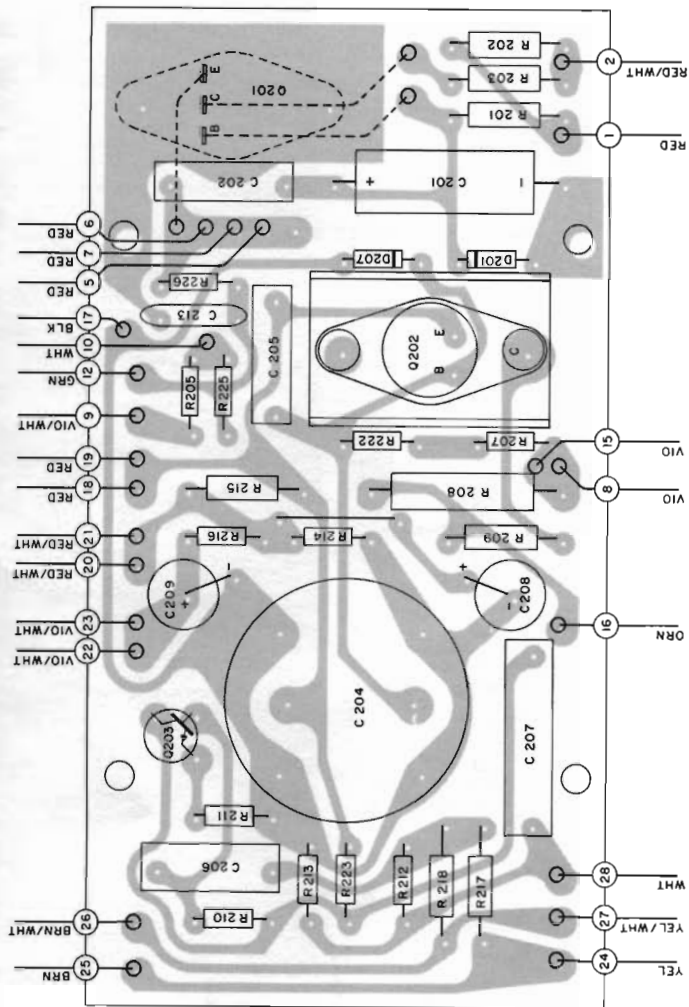

POWER SUPPLY / CENTER CHANNEL PRINTED CIRCUIT BOARD 044 - 007

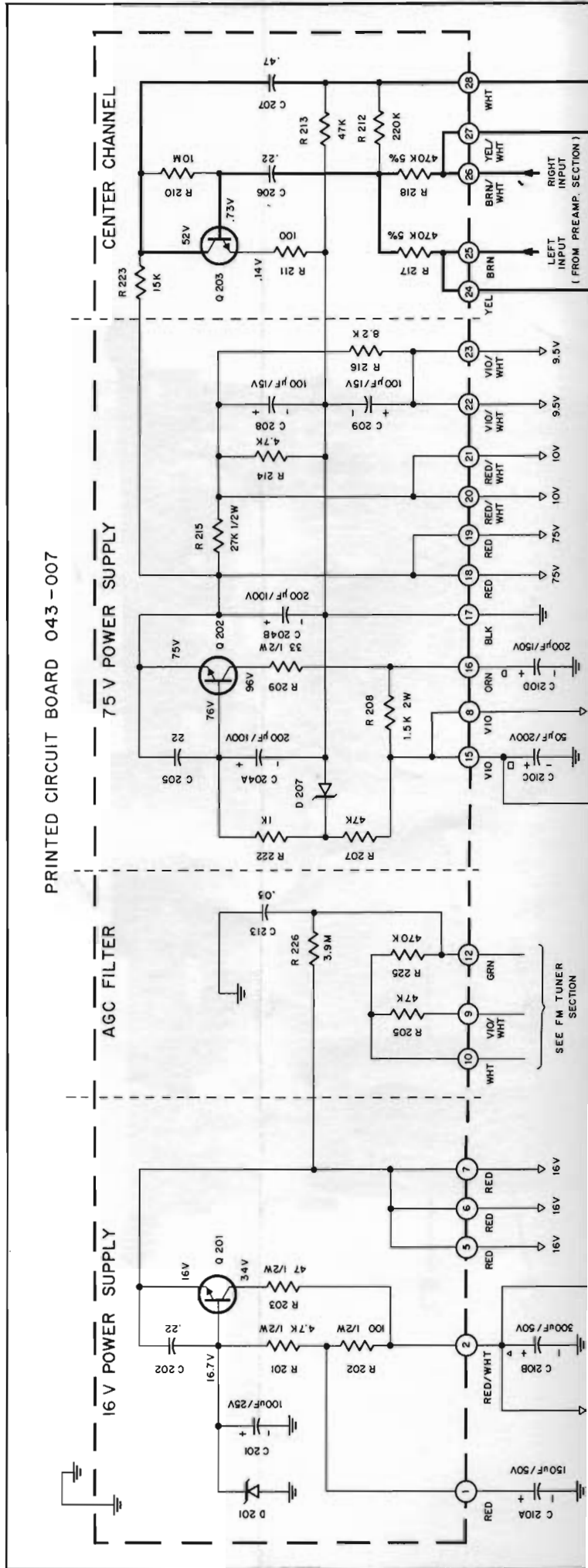

POWER SUPPLY / CENTER CHANNEL PRINTED CIRCUIT BOARD 044-007

PRINTED CIRCUIT BOARD 043-007

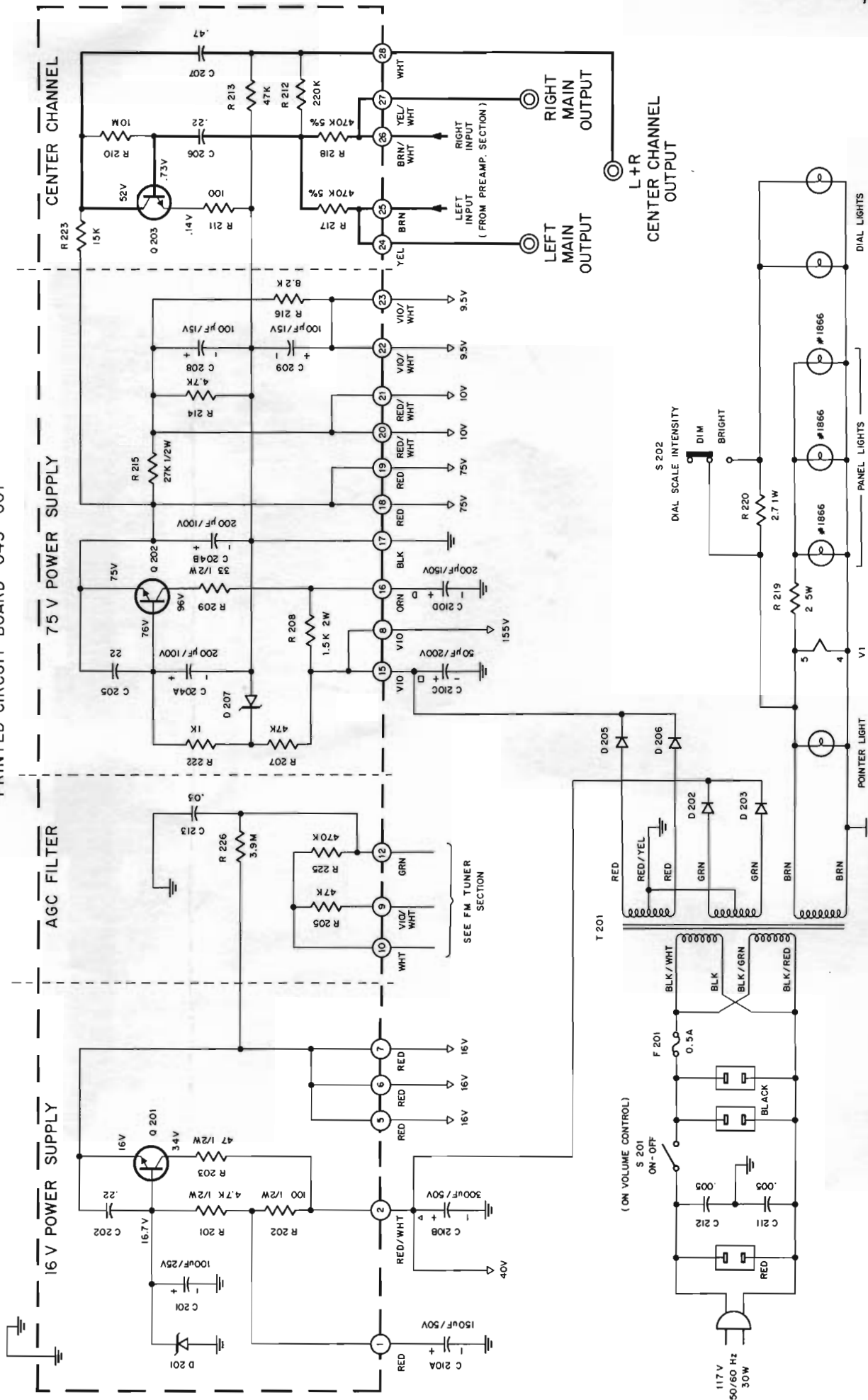

POWER SUPPLY / CENTER CHANNEL SECTION

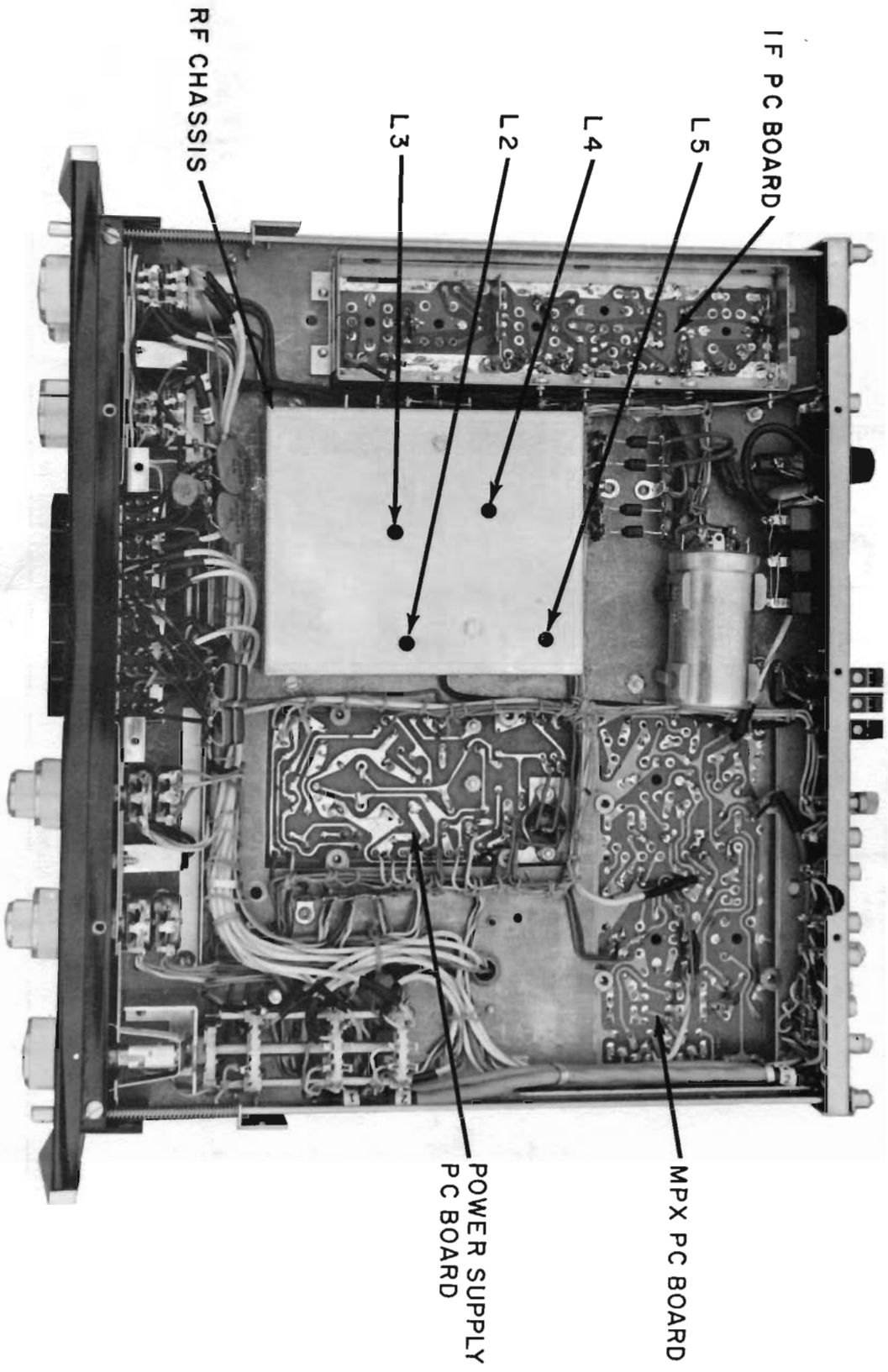

IF PC BOARD

L5

L4

L2

L3

RF CHASSIS

MPX PC BOARD

POWER SUPPLY
PC BOARD

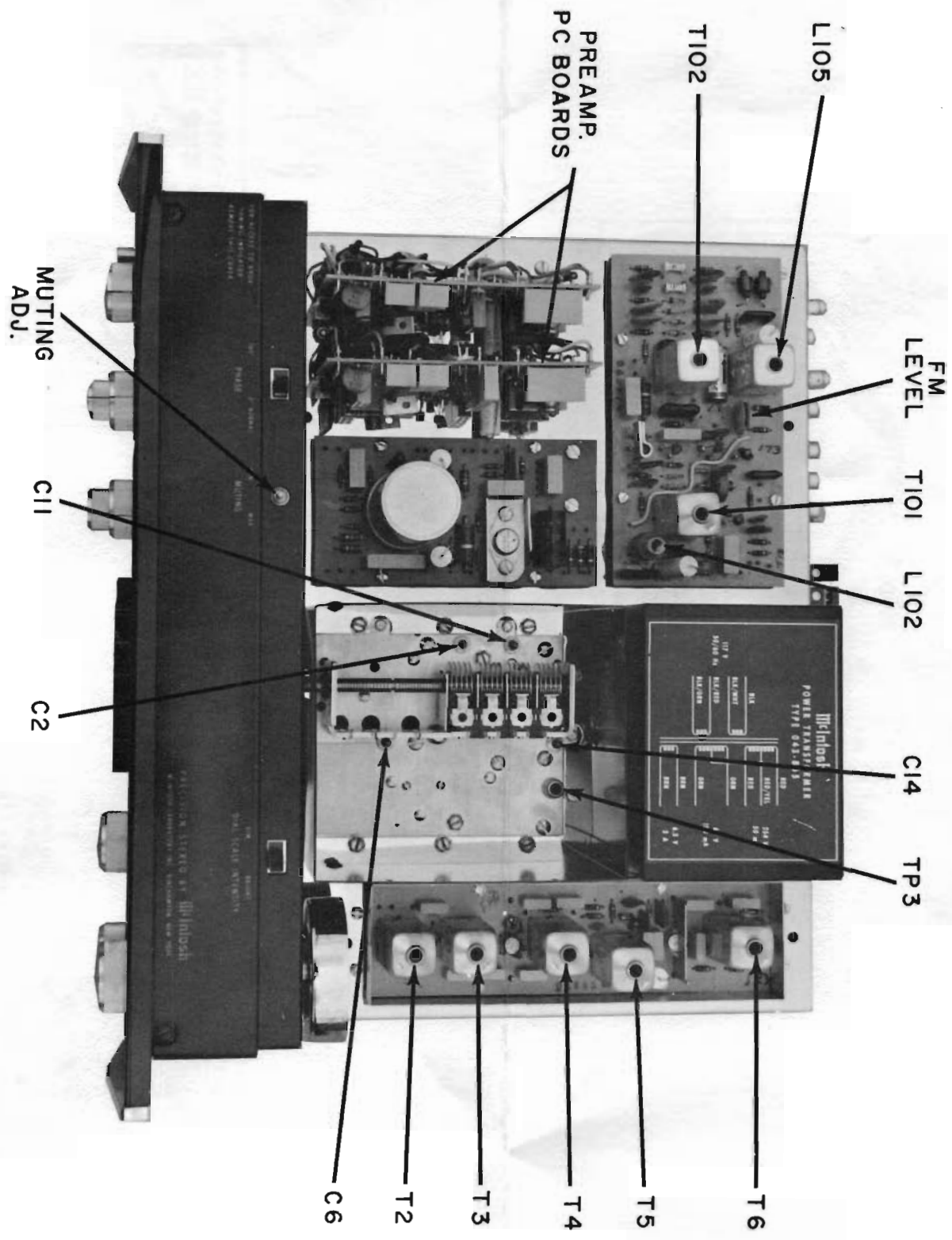

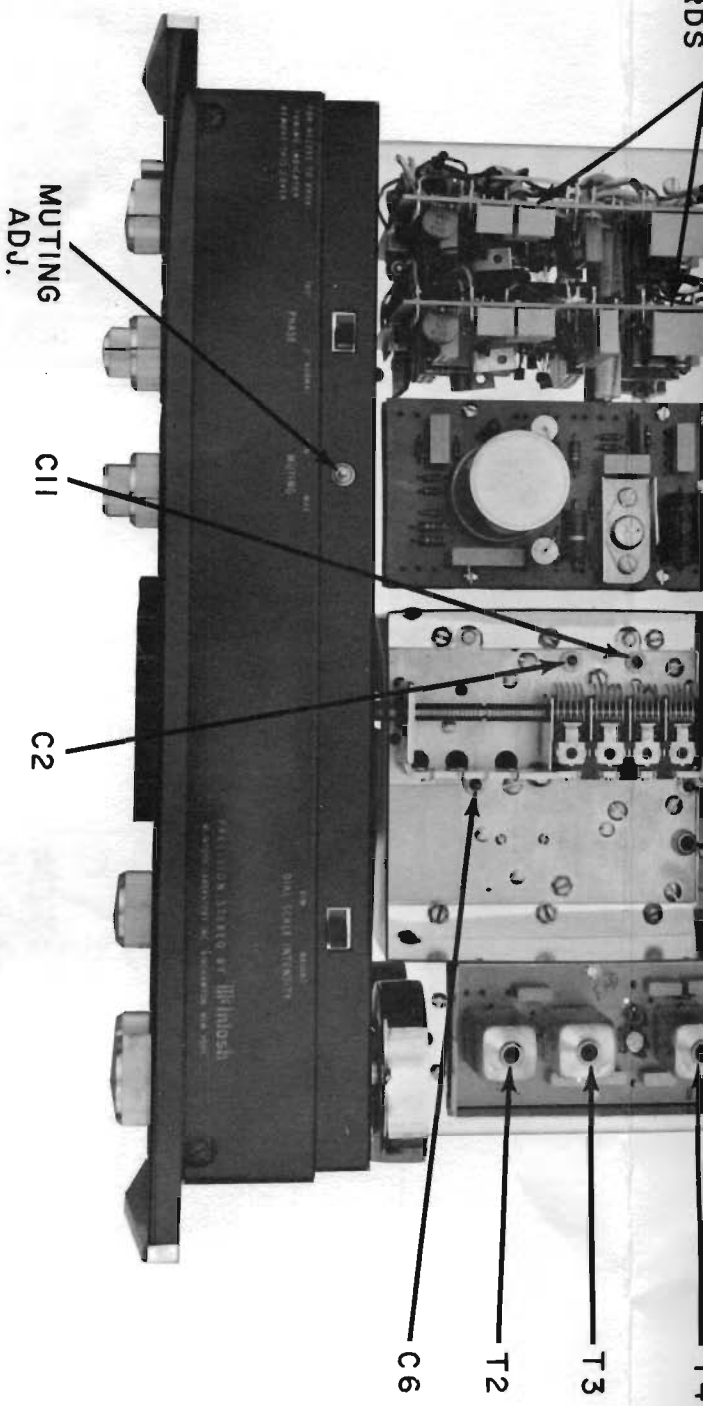

MX 114 ALIGNMENT INSTRUCTIONS

TEST EQUIPMENT REQUIRED

All McIntosh tuners are carefully aligned and tested at the factory using the finest available test equipment. All McIntosh tuners will meet their published specifications when shipped from the factory.

After extensive operation, or servicing, it may be desirable to realign the tuner circuits for best performance. The charts below give complete information on the circuit realignment procedure for the MX 114.

The test equipment listed (or its equivalent) is necessary to properly align an MX 114. The accuracy of the alignment will be directly related to the accuracy and calibration of the test equipment used.

If the necessary test equipment is not available, alignment should not be attempted. For additional information, contact Customer Service Department, McIntosh Laboratory, Inc., 2 Chambers Street, Binghamton, New York 13903 (telephone 607-723-3512).

Alignment should be done in the following order: FM-MPX

1. FM Signal Generator (Measurements 188 or equivalent)
2. VTVM
3. Multiplex Generator (RCA WR-51A or equivalent)
4. 10.7 MHz Generator (preferably crystal controlled)
5. Oscilloscope (Hewlett-Packard 120B or equivalent)
6. Harmonic Distortion Analyzer (Hewlett-Packard 333A or equivalent)

FM ALIGNMENT

STEP	TUNER DIAL SETTING	SIGNAL GENERATOR				INDICATOR		ADJUST	TEST LIMITS	REMARKS
		FREQ.	COUPLING	MODULATION	TYPE	CONNECTED TO				
1	Point of no interference or signal	10.7MHz	TP-3	FM +200KHz at 50Hz rate	Oscilloscope	TP #1	Top (secondary) and bottom (primary) cores of T1, T2, T3, T4	Optimum symmetry about 10.7 MHz and 75kHz markers.	If sweep generator has no built-in markers, use external marker generator by mixing with swept IF-signal at TP#3. First adjust Pri. and Sec. tuning slugs of T2, 3, 4, 5 for maximum amplitude. Note this amplitude on the scope. Then, readjust T3 and T4 (T2 and T5 if necessary) for 220kHz bandwidth and optimum symmetry, taking care that amplitude of scope pattern shall not decrease by more than 30%. Hold input signal to a low level to prevent limiting.	
2	Same	10.7MHz	Same	CW	VTVM	Pin 6 of T6	T6 primary (bottom core)	Maximum possible negative voltage		
3	Same	Same	Same	Same	Same	TP #2	T6 secondary (top core)	Adj. for 0 volts		
4	105MHz	105MHz	300 ohm antenna terminals w/matching network	400 cycles 75kHz deviation	VTVM connected to TP #1 and scope connected to L or R audio output		Oscillator Trimmer (C14)	Maximum negative voltage	As the tuner output increases, attenuate generator output to keep TP #1 voltage at a low level.	
5	90MHz	90MHz	Same	Same	Same	Same	Oscillator Coil (L5)	Same	Repeat steps 4 and 5 until dial calibration is accurate.	
6	105MHz	105MHz	Same	Same	Same	Same	Mixer trimmer, RF trimmer & antenna trimmer C11, C6, C2	Same		
7	90MHz	90MHz	Same	Same	Same	Same	Mixer, RF, and antenna coil tuning slugs L4, L3, L2	Same	Repeat steps 6 and 7 until TP#1 voltage is as high as possible. Connect a distortion analyzer to output jacks (either main or tape) and apply a 1mV input signal. Measure harmonic distortion and adjust T6 (primary) bottom slug for minimum distortion. (Should be less than 0.5%).	
8	105MHz & 90MHz	105MHz & 90MHz	Same	Same	VTVM connected to TP #1 and scope connected to L or R audio output.		Connect distortion analyzer to L or R output and reduce signal at antenna for -30dB total distortion and noise. Input signal required is IHPM usable sensitivity of the tuner (2.5 microvolts).	Step 8 is an overall sensitivity check. Adjust tuning control (R105) by reducing the signal input to 5 microvolts for a 2dB drop in audio output. Push in muting button (S302E) for this adjustment.		

is now usable sensitivity of the tuner (2.5 microvolts).

MULTIPLEX DECODER ALIGNMENT

STEP	TUNER DIAL SETTING	SIGNAL GENERATOR			INDICATOR		ADJUST	TEST LIMITS	REMARKS
		FREQ.	COUPLING	MODULATION	TYPE	CONNECTED TO			
1	100MHz	100MHz	300Ω antenna terminals w/ approx. 1000 microvolts signal w/** matching network	75KHz Deviation @ 67KHz	AC-VTVM Jack	L or R output	I105 (SCA Adj.)	Minimum output @ L or R output Jack	I105 (SCA adj.) is adjusted for minimum output with 67KHz modulation.
2	100MHz	100MHz	Same	19KHz pilot	AC-VTVM or oscilloscope w/very low cap. probe	T101, pin 2	I102 (19KHz phase adj.) & T101 (19KHz doubler)	Adjust for maximum AC voltage	Decrease pilot level so that 19KHz circuits are not being saturated.
3	Same	Same	Same	Same	Same	T102, Pin 1	T102 (Pri) & bottom (Sec) tuning slugs	Adj. for maximum AC voltage	Decrease pilot level so that 19KHz and 38KHz circuits are not being saturated. Mode switch must be in stereo position.
4	Same	Same	Same	1KHz (100% modulation) L or R only, pilot on	Same	L or R output Jack	T102, Bottom (Sec.) tuning slug.	30dB separation or more	First, modulate left channel and measure right channel output. Adjust T102 bottom - tuning slug (Sec.) for minimum right channel output. (maximum separation) Then, reverse channels and measure left channel separation. For this adjustment and measurement, no test lead should be connected to TP#2, and the dust cover over this section should be in place.
5	100MHz	100MHz	Same	1KHz (100% modulation) L or R only, pilot on	AC-VTVM Jack	L or R output Jack	Less than 10mV volts of residual		Adjust "FM-Level" control (R107) for 1 volt of audio output at tape-outputs. Then, turn off the modulator and measure the residual of the 10KHz and 38KHz frequencies.

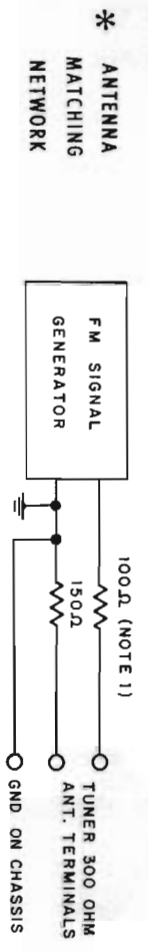

Note 1 : If signal generator has other than 50 ohm internal impedance, use a resistor of 150 ohms less internal generator impedance.

REPLACEMENT PARTS

All parts not listed are common items obtainable from radio parts jobbers.

Replacement parts may be obtained when ordered by PART NUMBER from:

McIntosh Laboratory Inc.
Customer Service Department
2 Chambers Street
Binghamton, New York 13903
(telephone 607-723-3512)

CAPACITORS

Symbol Number	Description	Part Number
C58	Elect 100 μ F 15V	066-127
C101	Mylar .22 μ F 250V	064-068
C107	Elect 100 μ F 15V	066-127
C111	Mylar .1 μ F 250V	064-067
C113	Mylar .22 μ F 250V	064-068
C127	Elect 100 μ F 15V	066-127
C201	Elect 100 μ F 25V	066-124
C202	Mylar .22 μ F 250V	064-068
C204	Elect 200/200 μ F 100V	066-129
C205,206	Mylar .22 μ F 250V	064-068
C207	Mylar .47 μ F 250V	064-069
C208,209	Elect 100 μ F 15V	066-127
C210	Elect 50/200/300/150 μ F 200/150/50/50V	066-128
C301,302	Mylar .47 μ F 250V	064-069
C305,306	Elect 10 μ F 50V	066-048
C307,308	Elect 10 μ F 50V	066-048
C315,316	Elect 100 μ F 15V	066-127
C317,318	Mylar .47 μ F 250V	064-069
C319,320	Mylar .22 μ F 250V	064-043
C323,324	Mylar .047 μ F 250V	064-066
C325,326	Mylar .47 μ F 250V	064-069
C327	Mylar .47 μ F 250V	064-069
C329,330	Mylar .047 μ F 250V	064-066
C331,332	Mylar .022 μ F 250V	064-065
C337,338	Mylar .1 μ F 250V	064-067
C340	Mylar .47 μ F 250V	064-069
C341,342	Mylar .047 μ F 250V	064-066
C343,344	Mylar .47 μ F 250V	064-069

DIODES

D1,2	Si. signal diode	070-022
D3,4	Si. signal diode	070-022
D7	Si. signal diode	070-022
D101,102	Si. signal diode	070-022

D103	Si. signal diode	070-022
D104,105	Ge. signal diode	070-003
D106,107	Ge. signal diode	070-003
D108	Bias diode	070-040
D201	Zener diode 16V	070-042
D202,203	Si. rectifier	070-030
D205,206	Si. rectifier	070-031
D207	Zener diode 75V	070-025

FUSE

F201	Fuse .5 Amp slo-blo	089-020
------	---------------------	---------

CHOKES

L2	FM antenna coil	122-069
L3	RF coil	122-070
L4	Mixer coil	122-071
L5	Local oscillator coil	122-071
L10	Choke 75 μ H	122-013
L14	Choke 1.2 μ H	122-011
L101	Choke 1 mH	122-065
L102	Filter coil (19 kHz phase)	122-067
L103,104	Filter coil (low pass)	122-015
L105	Filter coil (SCA adjust)	122-068

TRANSISTORS

Q1,2	Si. junction F.E.T.	132-049
Q3	Si. junction F.E.T.	132-049
Q5,6	Si. NPN transistor	132-015
Q101	Si. NPN transistor	132-057
Q102	Si. NPN transistor	132-052
Q103	Si. NPN transistor	132-041
Q104,105	Si. NPN transistor	132-057
Q106	Si. NPN transistor	132-042
Q201	Si. NPN transistor	132-046
Q202	Si. NPN transistor	132-516
Q203	Si. NPN transistor	132-026
Q301,302	Si. PNP transistor	132-031
Q303,304	Si. PNP transistor	132-031
Q305,306	Si. NPN transistor	132-026
Q307,308	Si. NPN transistor	132-054
Q309,310	Si. PNP transistor	132-029
Q311,312	Si. NPN transistor	132-054
Q313,314	Si. NPN transistor	132-057
Q315,316	Si. NPN transistor	132-042

POTENTIOMETERS

R105	Muting adjust	134-205
R107	FM level	134-197
R335	Volume control	134-202
R356	Balance control	134-201
R377,378	Tone control	134-203

RESISTORS

R219	Wirewound 2 Ω 5W	139-005
R220	Wirewound 2.7 Ω 1W	139-002

SWITCHES

S202	Dial scale intensity	148-023
S301	Input selector	146-130
S302	Pushbutton	150-004
S303	Phase	148-023

TRANSFORMERS

T1	Balun	043-226
T2	FM IF Transformer	162-034
T3	FM IF Transformer	162-035
T4	FM IF Transformer	162-034
T5	FM IF Transformer	162-035
T6	FM discriminator	162-036
T101	RF transformer (19kHz)	162-031
T102	RF transformer (38kHz)	162-039
T201	Power transformer	043-865

TUBES

V1	6HU6	165-025
----	------	---------

INTEGRATED CIRCUITS

IC1,2	Integrated circuit	133-001
-------	--------------------	---------

MODULES

	Tone control module	130-027
--	---------------------	---------

LAMPS

	#1828 (MPX lamp)	058-027
	#1866 (Front panel)	058-014
	Festoon lamp (dial glass)	058-032

FRONT PANEL & TRIM

	Front panel	044-006
	Front panel end caps	018-120
	Tuning knob	043-272

	Volume control knob	043-253
	Balance knob	043-253
	Input selector knob	043-253
	Bass knob (rear)	090-009
	Bass knob (front)	043-625
	Treble knob (rear)	090-009
	Treble knob (front)	043-625

MOUNTING SYSTEM

	Shelf bracket (right)	043-592
	Shelf bracket (left)	043-593
	Mounting template #100	038-179
	Hardware package	043-446

MISCELLANEOUS ITEMS

	FM dipole antenna	170-033
	Dial glass	044-019
	Pointer	043-876
	Dial cord (complete)	043-891
	Fuseholder	178-001
	AC power cord	170-021
	Shipping carton	043-988
	Owners manual	038-318
	Plastic feet	017-041
	Push terminal (antenna)	074-032
	Shorting plug	127-001
	Audio cable (6')	170-015
	LDR network	144-013